

ZASUWA ŚREDNIOCIŚNIENIOWA Z TRZPIENIEM WZNOSZONYM ZE STALI KUTEJ V-YR63; V- YL63

CHARAKTERYSTYKA:

- Średnica - 50 -500 mm;
- Ciśnienie - 63 bar;
- Temperatura - do 600°C;
- Medium - woda, para wodna i inne niepalne i chemicznie nieagresywne substancje.

WYKONANIE: typ / materiał kadłuba / rodzaj napędu / inne

Przykład: V-YR63 / --- / --- / ---

Przykład: V-YL63 / A / NA / ---

Materiał kadłuba	Znak	Rodzaj napędu	Znak	Inne	Znak
(P250GH) C 22.8	---	Kółko ręczne	---	-----	---
16Mo3	U	Napęd AUMA	NA		
13CrMo4-5	A	Napęd NWA	NW		
10CrMo9-10	B	Napęd MODACT	NM		
14MoV6-3	C				

ZASTOSOWANIE:

Zasuwy przeznaczone są do otwarcia i przerywania przepływu medium i nie wolno ich stosować do dławienia przepływu.

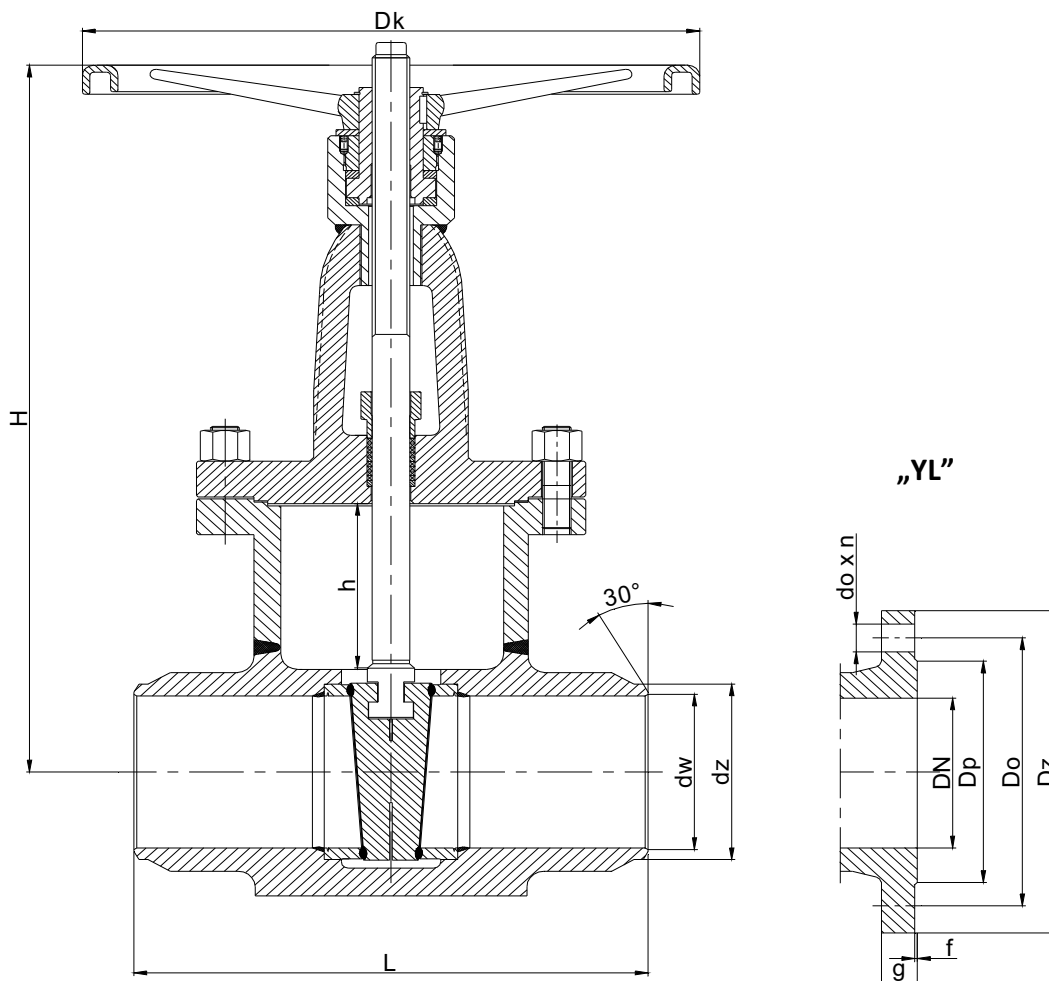

MATERIAŁY:

Wykonanie	Standardowe	U	A	B	C
Część	T _{MAX} 450°C	T _{MAX} 530°C	T _{MAX} 560°C	T _{MAX} 600°C	T _{MAX} 570°C
Kadłub, pokrywa, klin	(P250GH) C22.8 (1.0460)	16Mo3 (1.5415)	13CrMo4-5 (1.7335)	10CrMo9-10 (1.7380)	14MoV6-3 (1.7715)
Trzpień	X39CrMo17-1 (1.4122), X22CrMoV12-1 (1.4923)				
Pierścień kadłuba	Stellit				
Pierścień klina	Stellit				
Uszczelnienie dławnicy	Grafit				
Kółko	Stal				

WYMIARY:

DN	dz	dw	L	H	h	Dk	Masa	„YL”								
								Dz	Dp	Do	do	n	L	g.	f	Masa
50	62	54	250	365	65	200	28,20	180	102	135	22	4	250	26	3	39,00
65	77	69	290	435	78	250	40,90	205	122	160	22	8	290	26	3	56,00
80	91	81	310	460	93	250	48,70	215	138	170	22	8	310	28	3	62,00
100	117	104	350	535	112	315	70,60	250	162	200	26	8	350	30	3	97,00
125	144	130,5	400	630	146	315	133,90	295	188	240	30	8	400	34	3	164,00
150	172	156,5	450	800	174	315	215,10	345	218	280	33	12	450	36	3	265,00
200	223	204,5	550	860	233	400	260,00	415	285	345	36	12	550	42	3	335,00
250	278	255	650	1055	260	500	440,20	470	345	400	36	16	650	46	3	498,00
300	329	301	750	1179	310	500	604,60	530	410	460	36	16	750	52	4	677,00
350	362	330	850	1395	355	630	814,60	600	465	525	39	16	850	56	4	914,00
400	413	377						670	535	585	42	16	950	60	4	-
450	464	430,5	1350	1780	470	750	2800,00	-	-	-	-	-	-	-	-	-
500	516	474,5						800	615	705	48	20	1150	-	4	-

DANE TECHNICZNE:

Materiał kadłuba	PN	Najwyższe ciśnienie robocze przy temperaturze czynnika																	
		20°C	100°C	150°C	200°C	250°C	300°C	350°C	400°C	450°C	480°C	500°C	520°C	530°C	540°C	560°C	570°C	600°C	
(P250GH)C 22.8 (1.0460)	63	63,00	58,50	55,50	52,50	48,00	43,50	40,50	37,50	20,70	-	-	-	-	-	-	-	-	
16Mo3 (1.5415)	63	63,00	63,00	63,00	63,00	61,50	54,00	51,00	48,00	46,50	35,30	27,90	17,70	14,10	-	-	-	-	
13CrMo4-5 (1.7335)	63	63,00	63,00	63,00	63,00	63,00	62,70	60,00	57,00	54,00	46,20	41,10	28,20	23,40	18,30	12,00	9,90	-	
14MoV6-3 (1.7715)	63	63,00	63,00	63,00	63,00	63,00	63,00	63,00	62,70	60,90	60,50	57,90	44,70	39,30	33,90	25,80	21,90	-	
10CrMo9-10 (1.7380)	63	63,00	63,00	63,00	63,00	63,00	63,00	61,50	58,50	55,50	46,50	40,50	30,90	27,00	23,40	17,40	15,30	10,2	